

Product description

EFK – Electrical interlocking contactor

Introduction EFK

EFK is an electrical interlocking contactor with screw connections. The contactor is mounted in plastic encapsulation on a rail with connections for N and Earth (GND) via clamps.

- Accessory for fume cupboard controller FCL and fume cupboard monitor FLOCHECK V.
- Accessory for downflow bench control with 2 mode air flow controller FLL and downflow bench monitor FLOCHECK F.

Function

EFK may be ordered as an accessory and safety equipment for fume cupboard or downflow bench control. The contactor may be fitted for example to fume cupboard controller FCL which can cut the power to connected branch connectors in the event of an alarm of incorrect air speed in the hatch opening of the fume cupboard. The switch is reset manually via FCL and connected fume cupboard monitor FLOCHECK V.



EFK – Electrical interlocking contactor.

Technical specification

General.

Dimension

130 X 130 X 75 mm (LxWxH).

Weight

0.55 kg

Material

PC (polycarbonate) encapsulation

Colour

Grey

Type of contactor

24 VAC, 3-pole mini contactor with screw connections for single-phase or 3-phase. Inbuilt surge protection.

Electrical system

Max breaking current

single-phase 230 VAC 16A

Output

3.5 VA

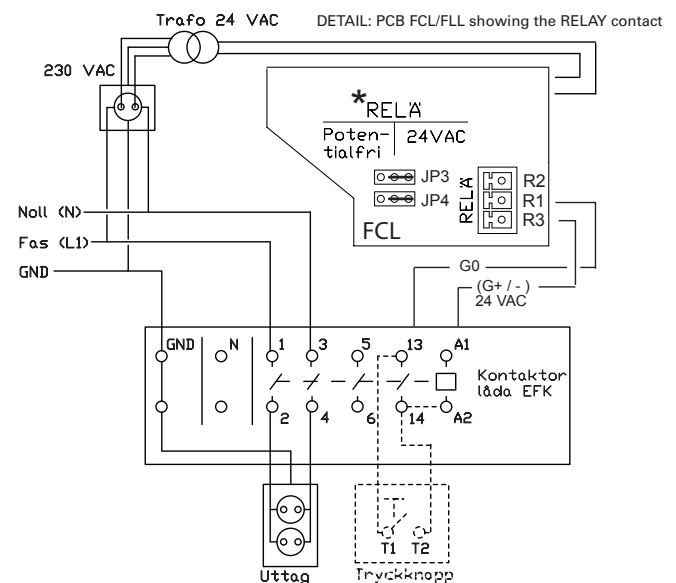

Connection diagram single-phase interlocking with output breaking voltage 24 VAC from FCL.

Product description

EFK – Electrical interlocking contactor

Additional product documentation EFK

Table 1: Additional documentation for EFK can be obtained via links on the product's website under Products at www.lindinvent.se

Document	Available	Not available	Comments
Installation Instruction	●		Shows connection with fume cupboard controller FCL
Start-up instruction		●	Not applicable
Maintenance instruction		●	Regarded as maintenance-free
External connection diagram	●		Not applicable
Environmental product declaration	●		Assessed by Byggvarubedomningen and Sundahus
User information		●	Not applicable
Modbus list		●	Not applicable
AMA text		●	None

Product documentation can be downloaded via
www.lindinvent.se/produkter/



Contact

www.lindinvent.se
Tel: 046-15 85 50

Lindinvent – Smarter indoor climate. Greener buildings.

The company offers products and systems for controlling ventilation, lighting, solar shading and local utilization. Equipment and climate solutions are being developed for offices, schools, hospitals, laboratories and similar working environments. Lindinvent's systems work together to provide high indoor comfort and the lowest possible energy use.